

DET.	QTY.	DESCRIPTION
ASM	1	SW02-BL08 SLIDE BASE
ASM	1	SW02-SL03 SLIDE SADDLE WITH LOCK HANDLE
\$02	1	ADJUSTABLE HANDLE, KHB-52, #10-32 THREAD x .59 LG.

REV.	REVISION DESCRIPTION	DATE	APPROVED

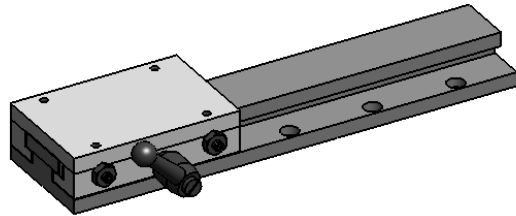
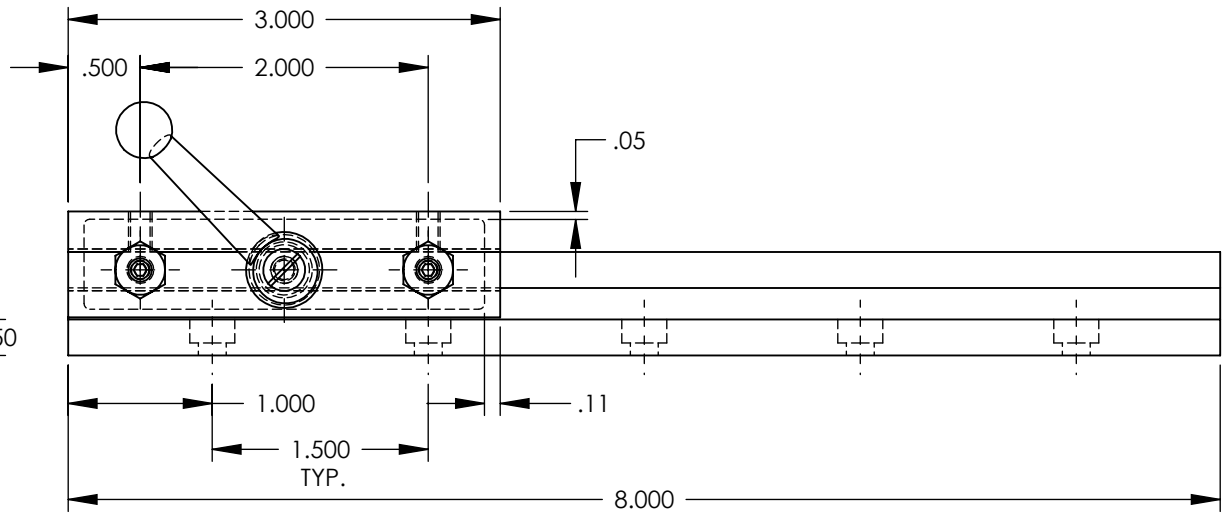
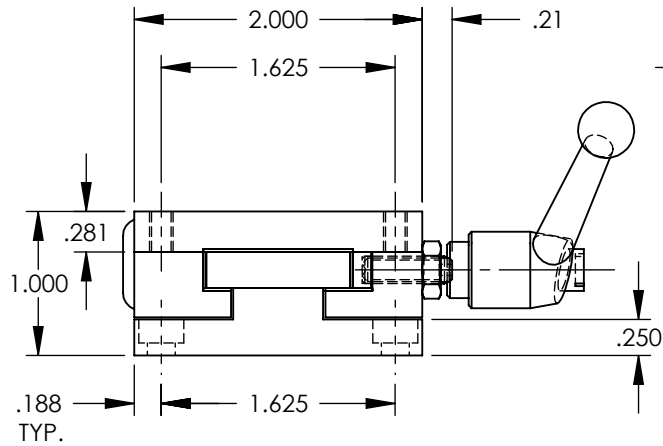
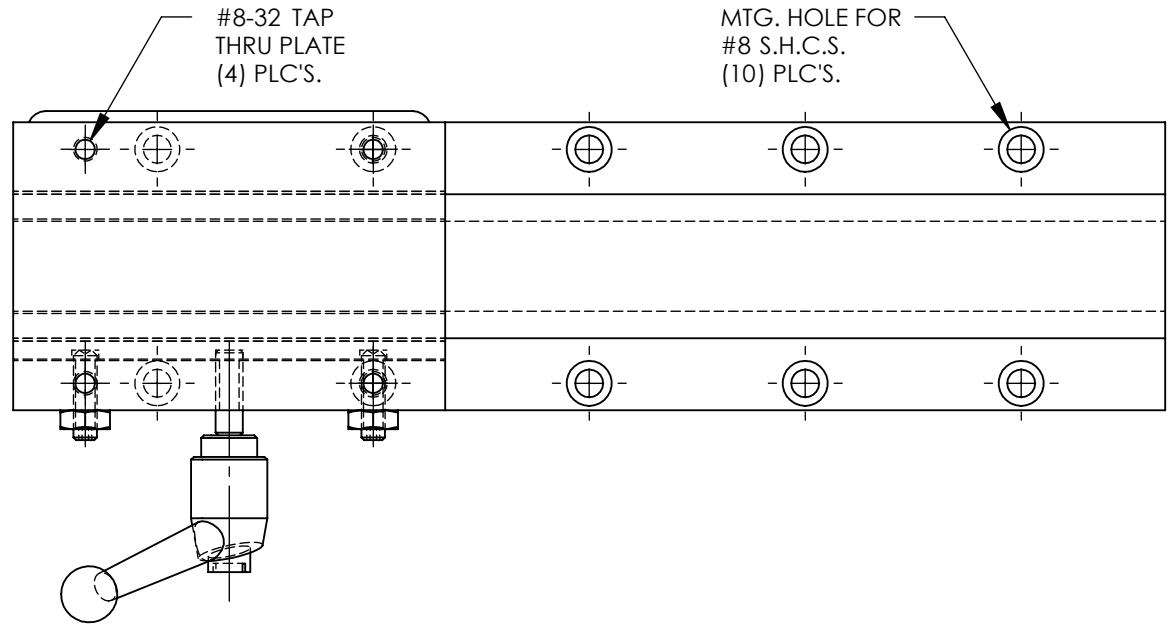

MODEL NAME: Gen2 SLIDE

<b>PROPRIETARY AND CONFIDENTIAL</b> THE INFORMATION CONTAINED IN THIS DRAWING IS THE SOLE PROPERTY OF AUTOMATED INDUSTRIAL MOTION. ANY REPRODUCTION IN PART OR AS A WHOLE WITHOUT THE WRITTEN PERMISSION OF AUTOMATED INDUSTRIAL MOTION IS PROHIBITED.	NAME	DATE	<b>DURA-BOND SLIDE</b> TITLE:			
	DRAWN	JMW			06/08/11	GEN II SLIDE
	CHECKED			SIZE	DWG. NO.	
	ENG APPR.	Wierengo	06/15/11	<b>A</b>	SW02-SL03-BL08-LH	-
MATERIAL	UNLESS OTHERWISE SPECIFIED:		SCALE: NONE			
ASSEMBLY	DIMENSIONS ARE IN INCHES		WEIGHT: 3.0 lbs.			
HARDEN	TOLERANCES:		SHEET 1 OF 1			
FINISH	ANGULAR: MACH ±1/2 DEGREE					
	TWO PLACE DECIMAL ±.010					
	THREE PLACE DECIMAL ±.005					
	FOUR PLACE DECIMAL ±.0005					