

DET.	QTY.	DESCRIPTION
ASM	1	SW02-BL08 SLIDE BASE
ASM	1	SW02-SL06 SLIDE SADDLE WITH LOCK HANDLES
\$02	2	ADJUSTABLE HANDLE, KHB-52, #10-32 THREAD x .59 LG.

REV.	REVISION DESCRIPTION	DATE	APPROVED

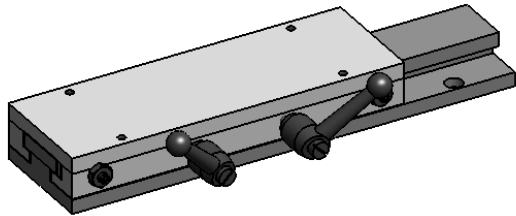
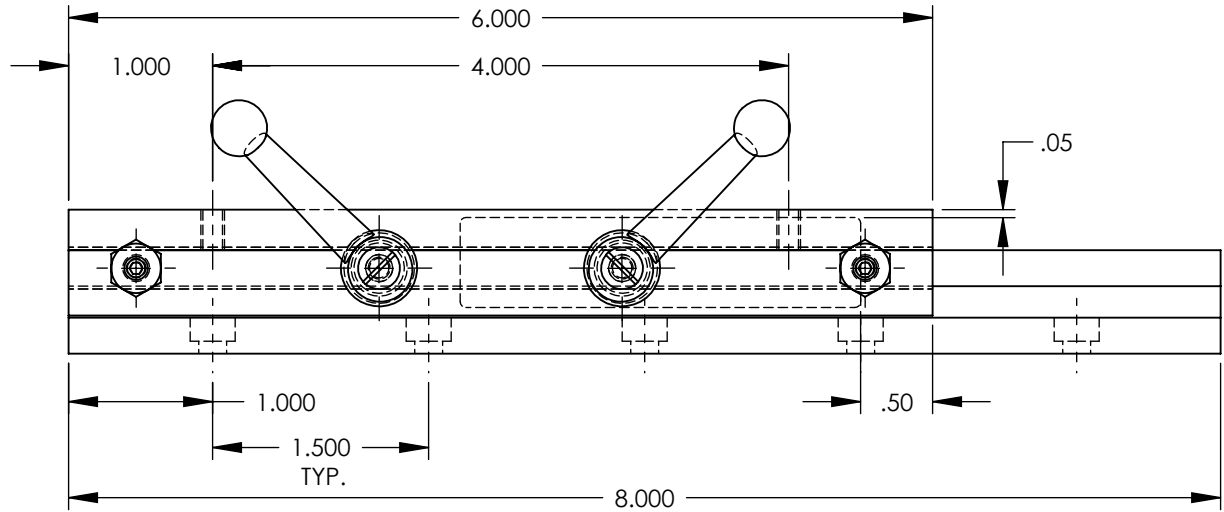
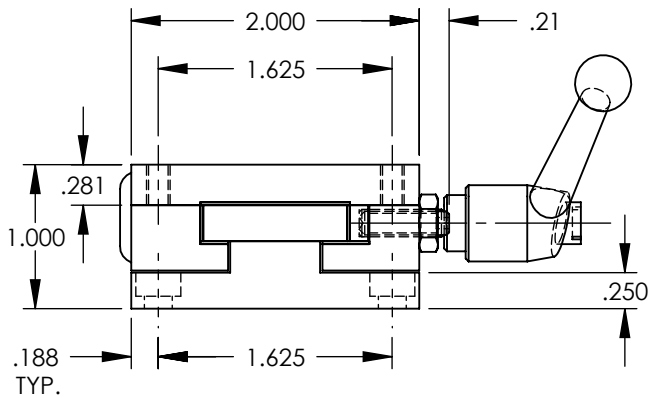
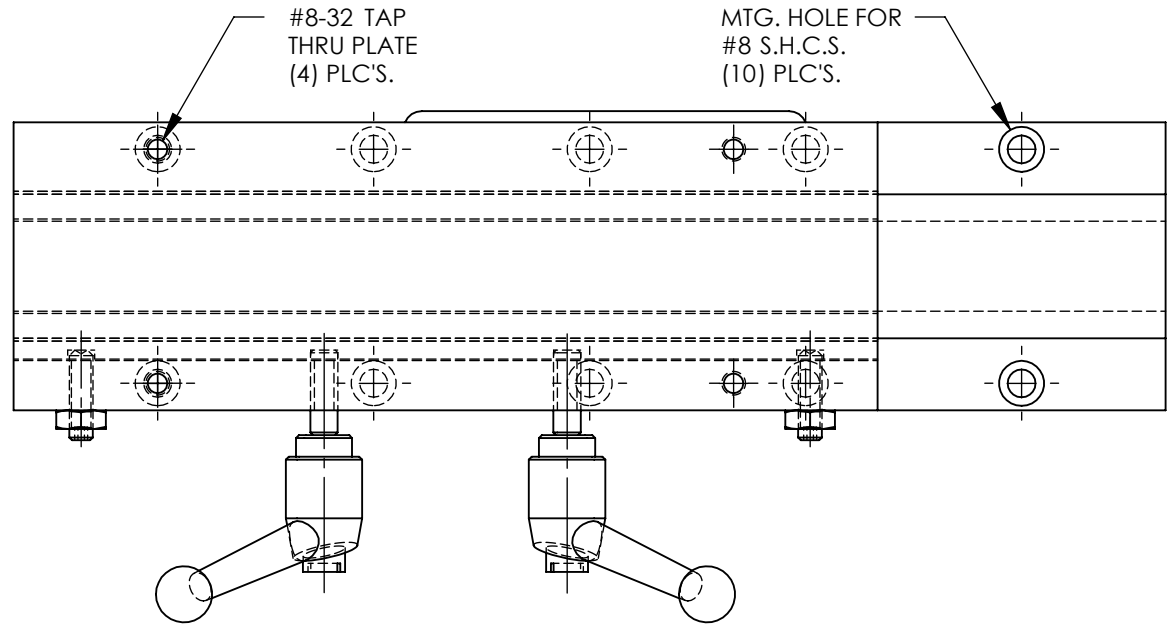

MODEL NAME: Gen2 SLIDE

<b>PROPRIETARY AND CONFIDENTIAL</b> THE INFORMATION CONTAINED IN THIS DRAWING IS THE SOLE PROPERTY OF AUTOMATED INDUSTRIAL MOTION. ANY REPRODUCTION IN PART OR AS A WHOLE WITHOUT THE WRITTEN PERMISSION OF AUTOMATED INDUSTRIAL MOTION IS PROHIBITED.	NAME	DATE	<b>DURA-BOND SLIDE</b> TITLE:			
	DRAWN	JMW			06/08/11	GEN II SLIDE
	CHECKED			SIZE DWG. NO. REV <b>A</b> SW02-SL06-BL08-LH -		
	ENG APPR.	Wierengo	06/15/11		SCALE: NONE	WEIGHT: 3.9 lbs.
	UNLESS OTHERWISE SPECIFIED: DIMENSIONS ARE IN INCHES TOLERANCES: ANGULAR: MACH ±1/2 DEGREE TWO PLACE DECIMAL ±.010 THREE PLACE DECIMAL ±.005 FOUR PLACE DECIMAL ±.0005					
MATERIAL	ASSEMBLY					
HARDEN						
FINISH						