

DET.	QTY.	DESCRIPTION
ASM	1	SW03-BL06 SLIDE BASE
ASM	1	SW03-SL04 SLIDE SADDLE

REV.	REVISION DESCRIPTION	DATE	APPROVED

#10-32 TAP
THRU PLATE
(4) PLC'S.

MTG. HOLE FOR
#10 S.H.C.S.
(6) PLC'S.

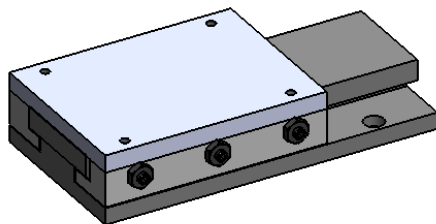
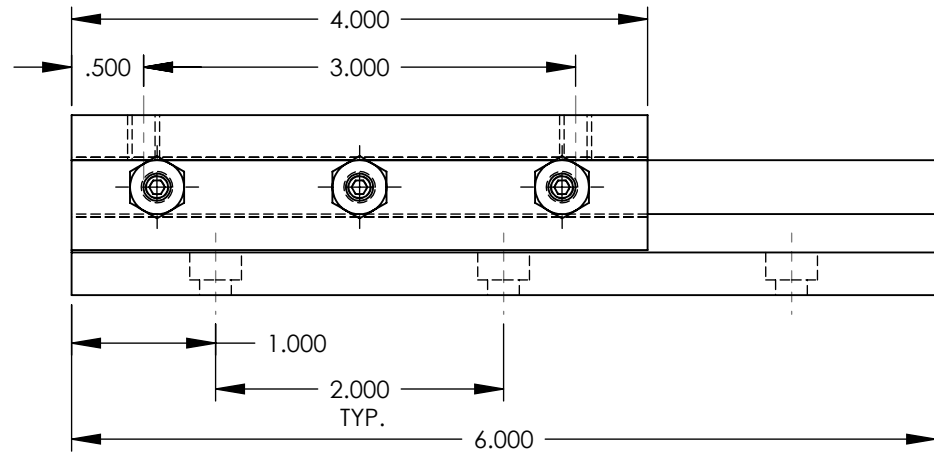
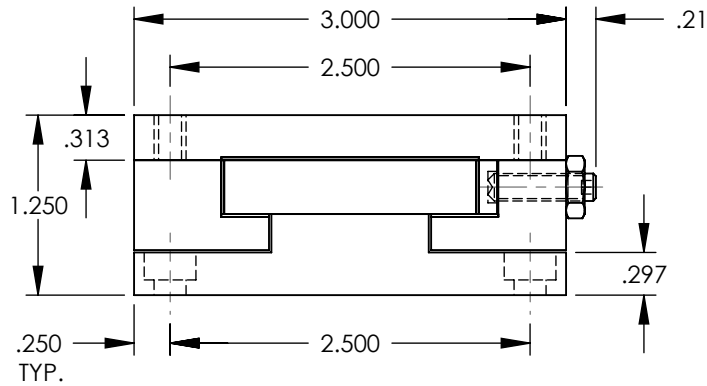
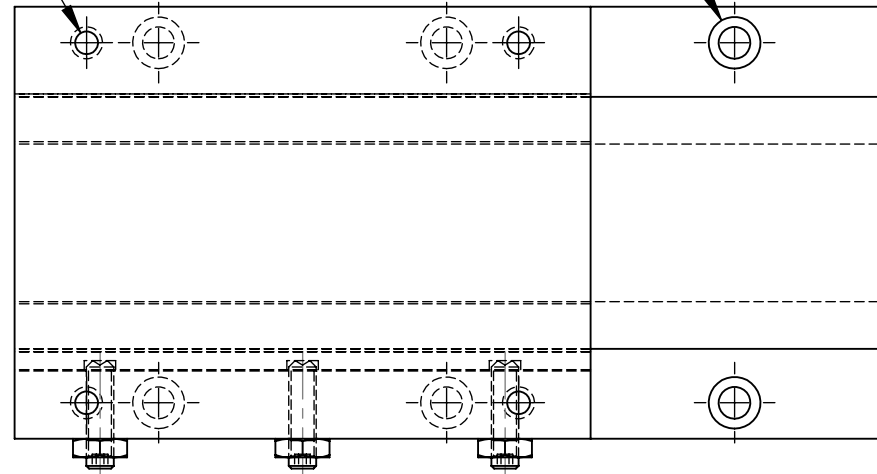

MODEL NAME: Gen2 SLIDE

PROPRIETARY AND CONFIDENTIAL
THE INFORMATION CONTAINED IN THIS DRAWING IS THE SOLE PROPERTY OF AUTOMATED INDUSTRIAL MOTION. ANY REPRODUCTION IN PART OR AS A WHOLE WITHOUT THE WRITTEN PERMISSION OF AUTOMATED INDUSTRIAL MOTION IS PROHIBITED.

MATERIAL
ASSEMBLY
HARDEN
FINISH

	NAME	DATE
DRAWN	JMW	9/3/10
CHECKED		
ENG APPR.	Wierengo	10/1/10

UNLESS OTHERWISE SPECIFIED:
DIMENSIONS ARE IN INCHES
TOLERANCES:
ANGULAR: MACH ± 1/2 DEGREE
TWO PLACE DECIMAL ±.010
THREE PLACE DECIMAL ±.005
FOUR PLACE DECIMAL ±.0005

DURA-BOND SLIDE

TITLE:
GEN II SLIDE

SIZE	DWG. NO.	REV
A	SW03-SL04-BL06	-

SCALE: NONE WEIGHT: 4.2 lbs. SHEET 1 OF 1