

DET.	QTY.	DESCRIPTION
ASM	1	SW04-BL12 SLIDE BASE
ASM	1	SW04-SL06 SLIDE SADDLE

REV.	REVISION DESCRIPTION	DATE	APPROVED

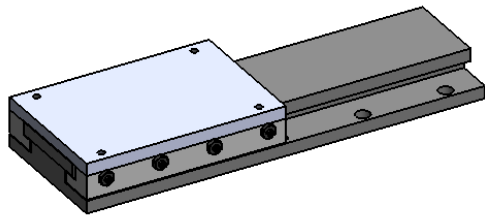
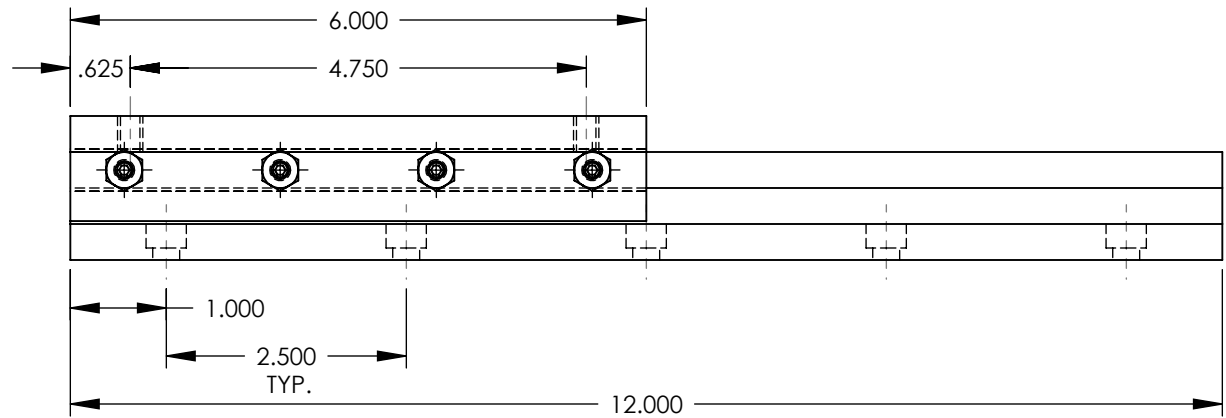
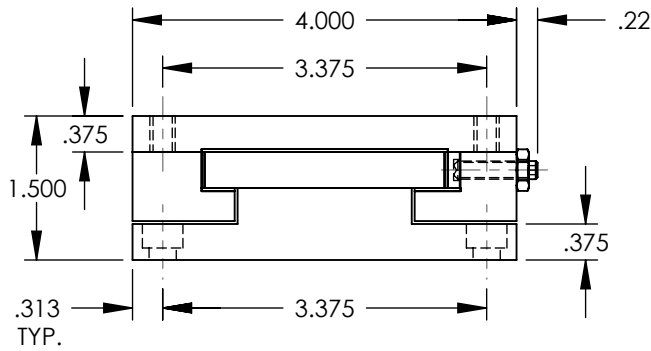
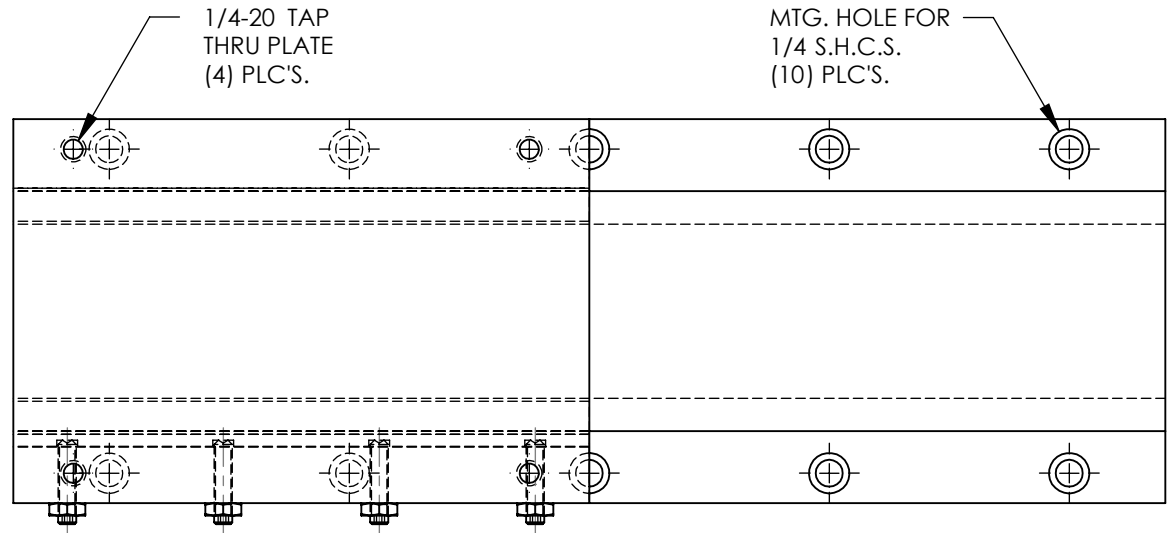

MODEL NAME: Gen2 SLIDE

PROPRIETARY AND CONFIDENTIAL THE INFORMATION CONTAINED IN THIS DRAWING IS THE SOLE PROPERTY OF AUTOMATED INDUSTRIAL MOTION. ANY REPRODUCTION IN PART OR AS A WHOLE WITHOUT THE WRITTEN PERMISSION OF AUTOMATED INDUSTRIAL MOTION IS PROHIBITED.	NAME	DATE	DURA-BOND SLIDE TITLE: <h2 style="text-align: center;">GEN II SLIDE</h2>		
	DRAWN	JMW			9/3/10
	CHECKED				
	ENG APPR.	Wierengo			10/1/10
MATERIAL	UNLESS OTHERWISE SPECIFIED:		SIZE	DWG. NO.	REV
ASSEMBLY	DIMENSIONS ARE IN INCHES		A	SW04-SL06-BL12	-
HARDEN	TOLERANCES:				
FINISH	ANGULAR: MACH ±1/2 DEGREE				
	TWO PLACE DECIMAL ±.010 THREE PLACE DECIMAL ±.005 FOUR PLACE DECIMAL ±.0005				
SCALE: NONE			WEIGHT: 12.7 lbs.		SHEET 1 OF 1