

DET.	QTY.	DESCRIPTION
ASM	1	SW06-BL16 SLIDE BASE
ASM	1	SW06-SL12 SLIDE SADDLE WITH LOCK HANDLES
\$02	2	ADJUSTABLE HANDLE , KHB-62, 5/16-18 THREAD x 1.18 LG.

REV.	REVISION DESCRIPTION	DATE	APPROVED
------	----------------------	------	----------

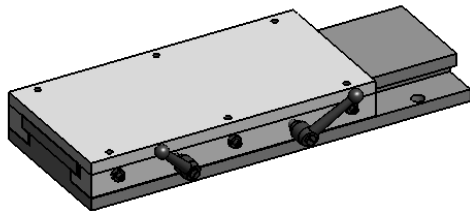
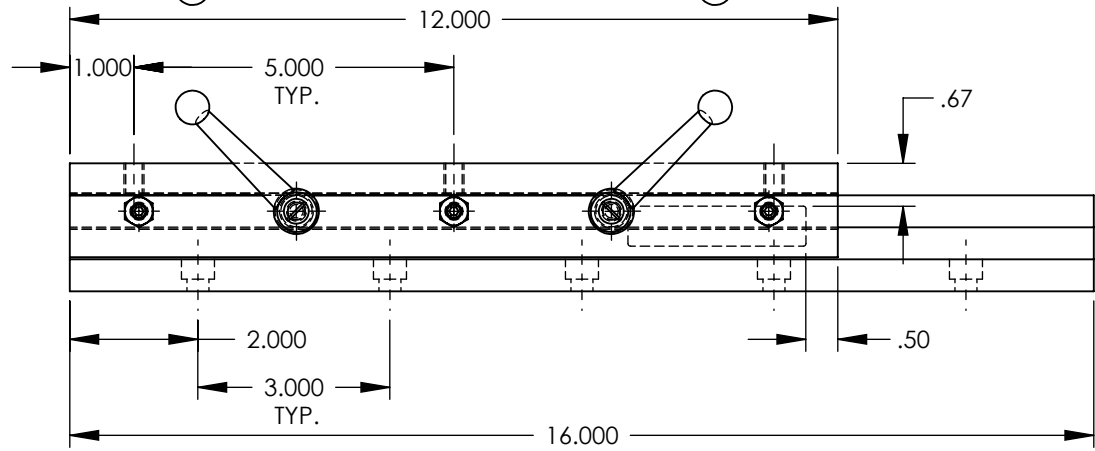
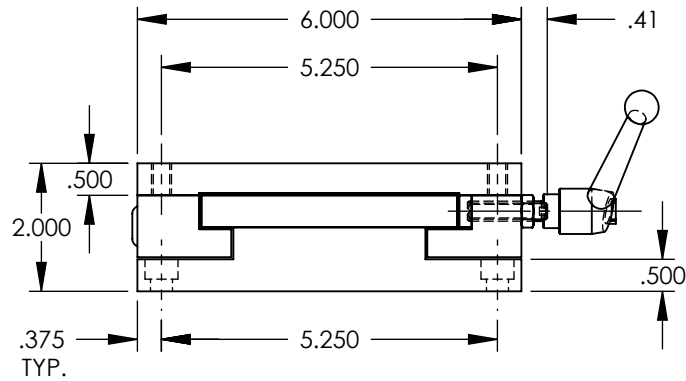
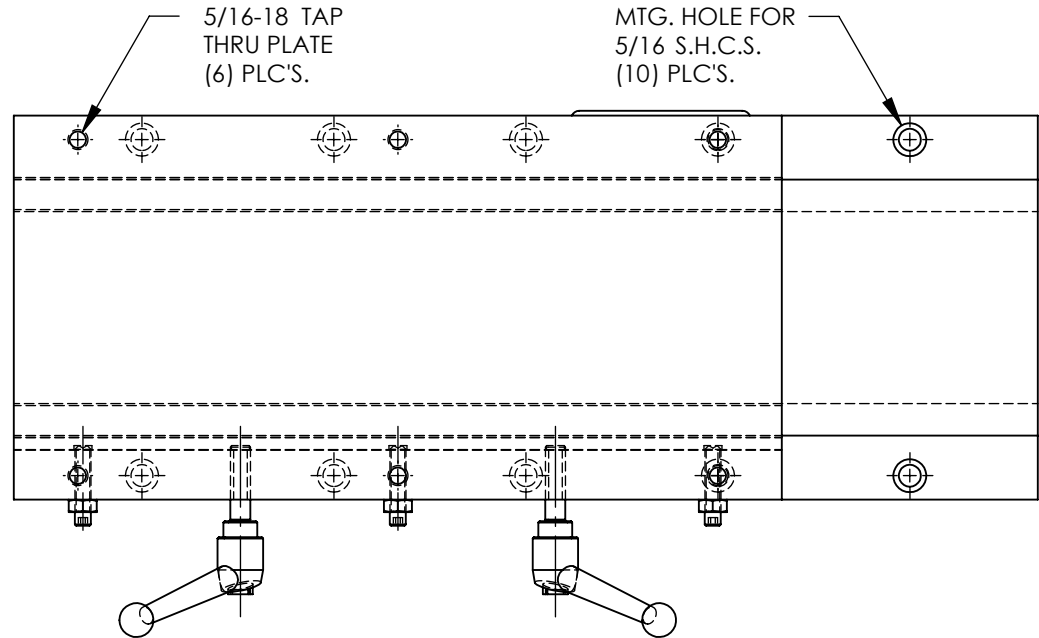

MODEL NAME: Gen2 SLIDE

PROPRIETARY AND CONFIDENTIAL THE INFORMATION CONTAINED IN THIS DRAWING IS THE SOLE PROPERTY OF AUTOMATED INDUSTRIAL MOTION. ANY REPRODUCTION IN PART OR AS A WHOLE WITHOUT THE WRITTEN PERMISSION OF AUTOMATED INDUSTRIAL MOTION IS PROHIBITED.	NAME	DATE	DURA-BOND SLIDE TITLE:			
	DRAWN	JMW			06/08/11	GEN II SLIDE
	CHECKED			SIZE	DWG. NO.	
	ENG APPR.	Wierengo	06/15/11	A	SW06-SL12-BL16-LH	-
MATERIAL	UNLESS OTHERWISE SPECIFIED:		SCALE: NONE		WEIGHT: 47.7 lbs.	SHEET 1 OF 1
ASSEMBLY	DIMENSIONS ARE IN INCHES					
HARDEN	TOLERANCES:					
FINISH	ANGULAR: MACH ±1/2 DEGREE					
	TWO PLACE DECIMAL ±.010					
	THREE PLACE DECIMAL ±.005					
	FOUR PLACE DECIMAL ±.0005					