

DET.	QTY.	DESCRIPTION
ASM	1	SW09-BL18 SLIDE BASE
ASM	1	SW09-SL14 SLIDE SADDLE

REV.	REVISION DESCRIPTION	DATE	APPROVED

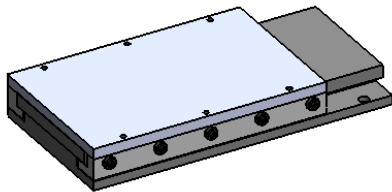
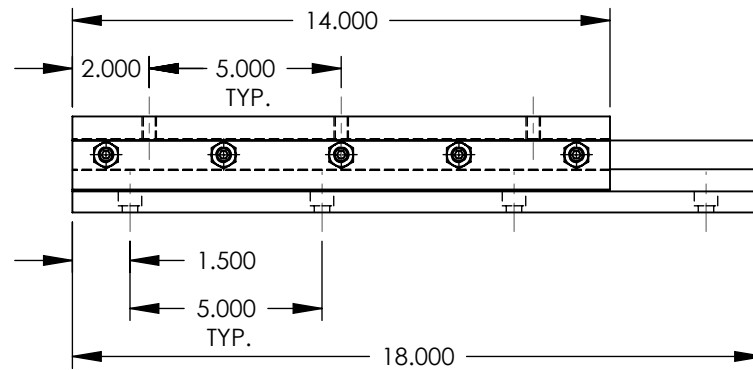
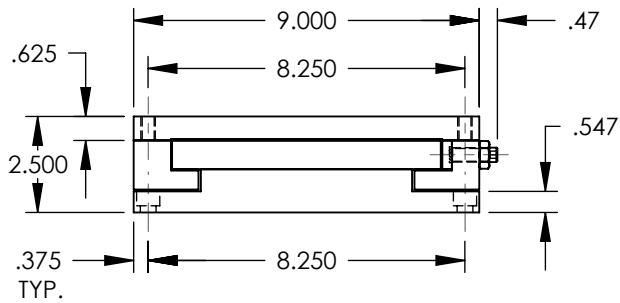
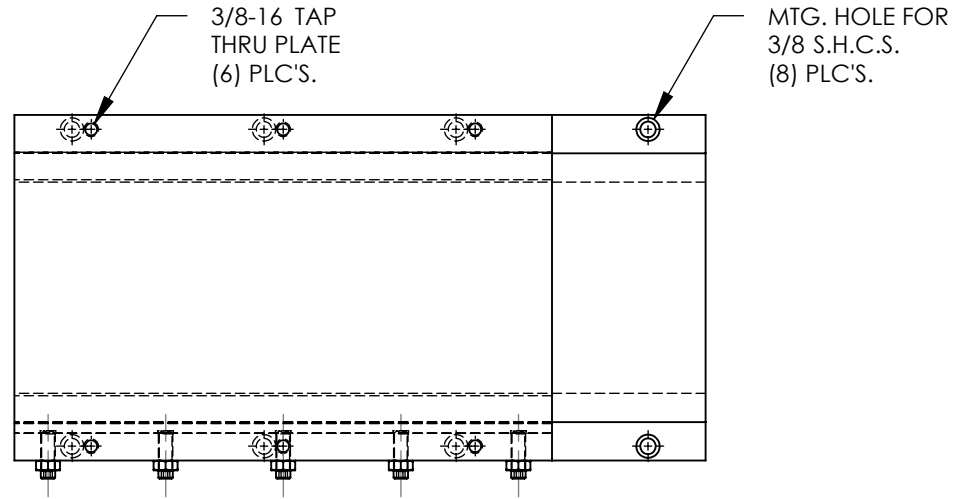

MODEL NAME: Gen2 SLIDE

**PROPRIETARY AND CONFIDENTIAL**  
 THE INFORMATION CONTAINED IN THIS DRAWING IS THE SOLE PROPERTY OF AUTOMATED INDUSTRIAL MOTION. ANY REPRODUCTION IN PART OR AS A WHOLE WITHOUT THE WRITTEN PERMISSION OF AUTOMATED INDUSTRIAL MOTION IS PROHIBITED.

MATERIAL  
**ASSEMBLY**  
 HARDEN  
 FINISH

	NAME	DATE
DRAWN	JMW	9/3/10
CHECKED		
ENG APPR.	Wierengo	10/1/10

UNLESS OTHERWISE SPECIFIED:

DIMENSIONS ARE IN INCHES  
 TOLERANCES:  
 ANGULAR: MACH ±1/2 DEGREE  
 TWO PLACE DECIMAL ±.010  
 THREE PLACE DECIMAL ±.005  
 FOUR PLACE DECIMAL ±.0005

**DURA-BOND SLIDE**

TITLE:

GEN II SLIDE

SIZE	DWG. NO.	REV
<b>A</b>	SW09-SL14-BL18	-

SCALE: NONE	WEIGHT: 81.4 lbs.	SHEET 1 OF 1
-------------	-------------------	--------------