

DET.	QTY.	DESCRIPTION
ASM	1	SW09-BL24 SLIDE BASE
ASM	1	SW09-SL14 SLIDE SADDLE WITH LOCK HANDLES
\$02	2	ADJUSTABLE HANDLE , KHB-102, 1/2-13 THREAD x 1.18 LG.

REV.	REVISION DESCRIPTION	DATE	APPROVED
------	----------------------	------	----------

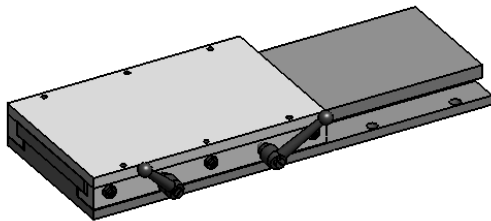
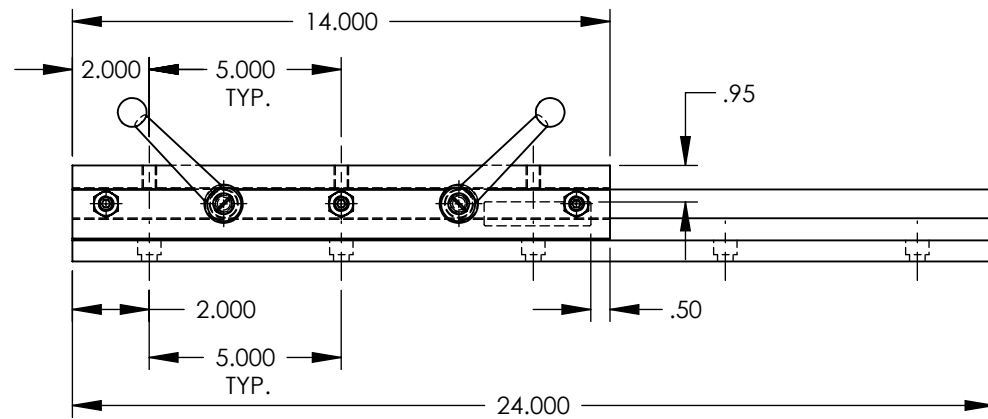
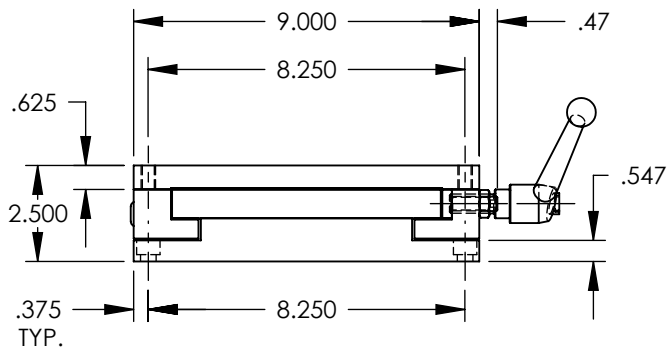
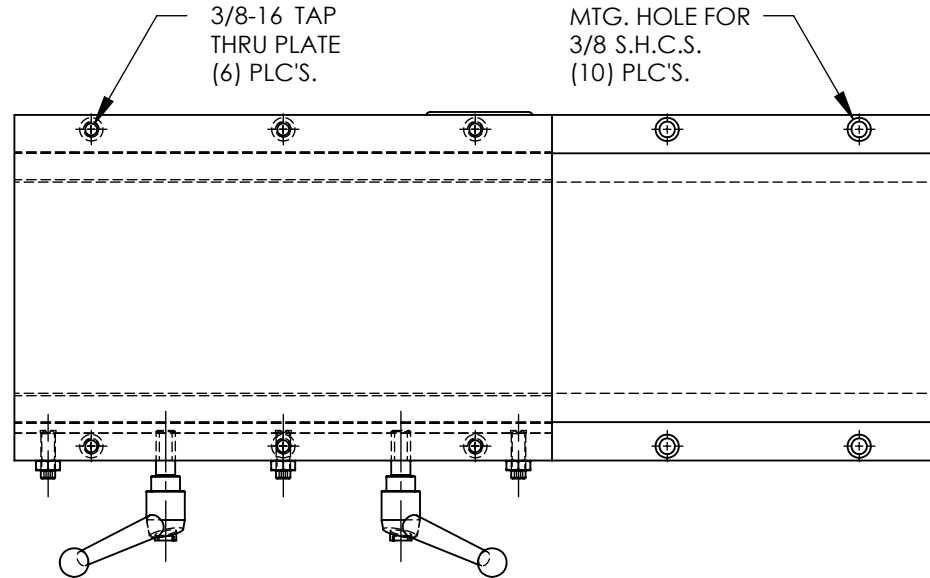

MODEL NAME: Gen2 SLIDE

**PROPRIETARY AND CONFIDENTIAL**  
 THE INFORMATION CONTAINED IN THIS DRAWING IS THE SOLE PROPERTY OF AUTOMATED INDUSTRIAL MOTION. ANY REPRODUCTION IN PART OR AS A WHOLE WITHOUT THE WRITTEN PERMISSION OF AUTOMATED INDUSTRIAL MOTION IS PROHIBITED.

MATERIAL  
**ASSEMBLY**  
 HARDEN  
 FINISH

	NAME	DATE
DRAWN	JMW	06/08/11
CHECKED		
ENG APPR.	Wierengo	06/15/11

UNLESS OTHERWISE SPECIFIED:  
 DIMENSIONS ARE IN INCHES  
 TOLERANCES:  
 ANGULAR: MACH ±1/2 DEGREE  
 TWO PLACE DECIMAL ±.010  
 THREE PLACE DECIMAL ±.005  
 FOUR PLACE DECIMAL ±.0005

**DURA-BOND SLIDE**

TITLE:  
**GEN II SLIDE**

SIZE	DWG. NO.	REV
<b>A</b>	SW09-SL14-BL24-LH	-

SCALE: NONE    WEIGHT: 126.7 lbs.    SHEET 1 OF 1