

DET.	QTY.	DESCRIPTION
ASM	1	SW09-BL32 SLIDE BASE
ASM	1	SW09-SL14 SLIDE SADDLE WITH LOCK HANDLES
\$02	2	ADJUSTABLE HANDLE , KHB-102, 1/2-13 THREAD x 1.18 LG.

REV.	REVISION DESCRIPTION	DATE	APPROVED

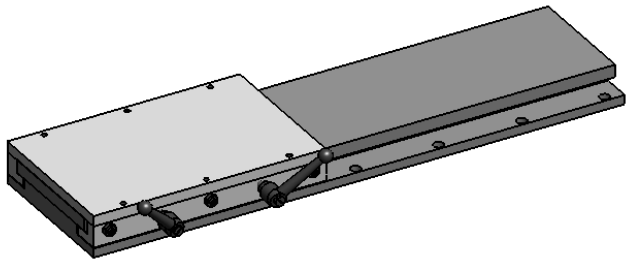
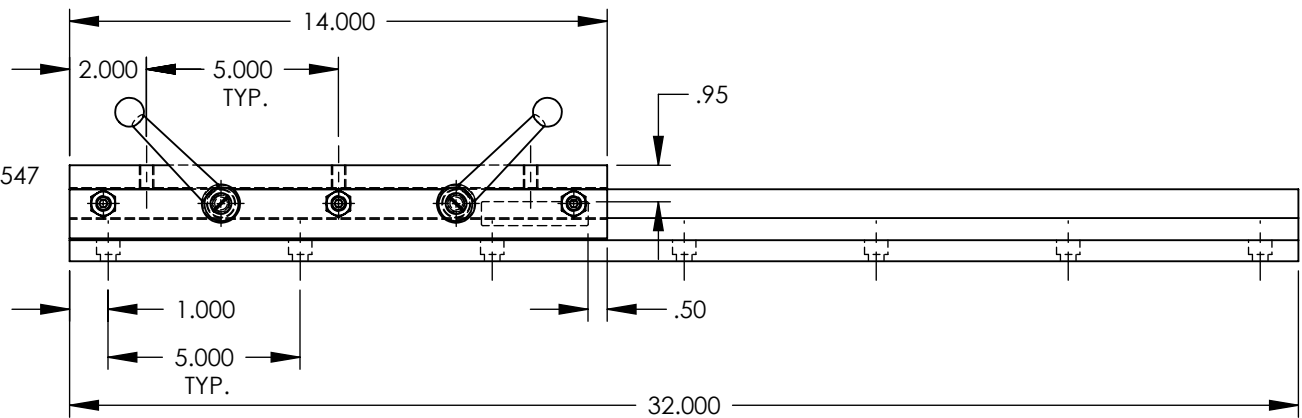
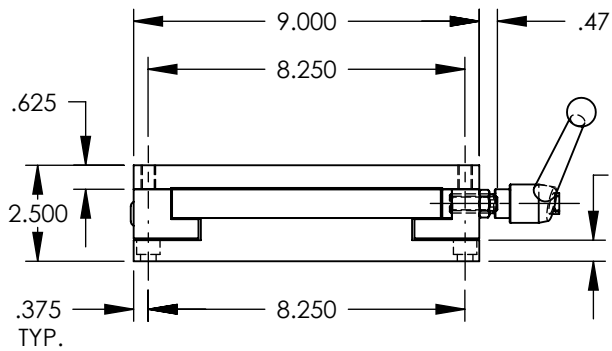
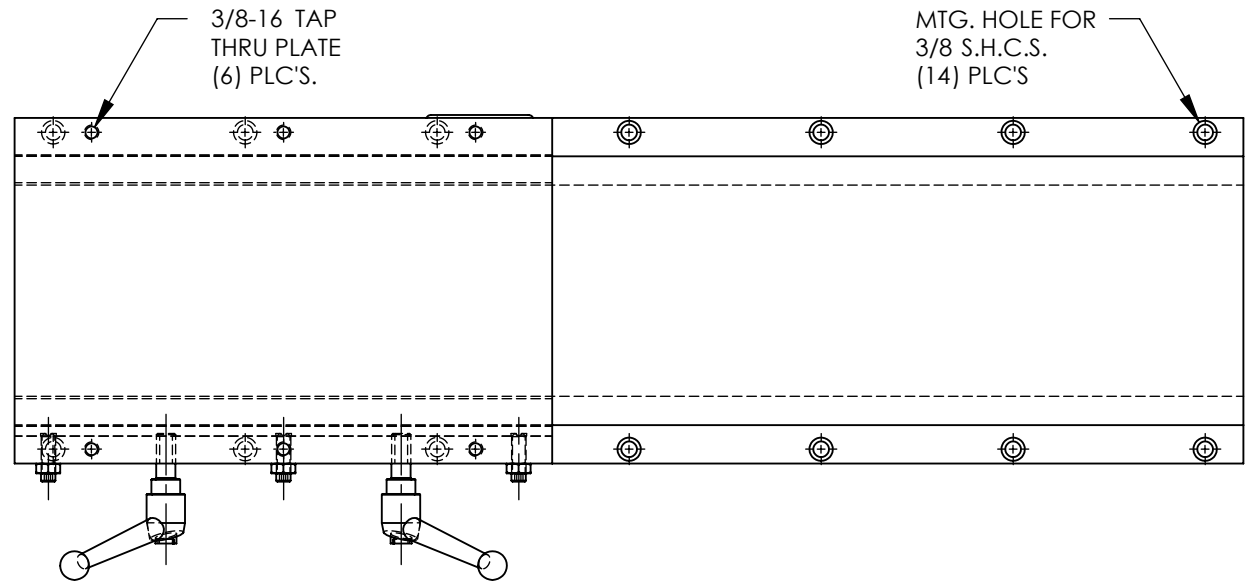

MODEL NAME: Gen2 SLIDE

PROPRIETARY AND CONFIDENTIAL THE INFORMATION CONTAINED IN THIS DRAWING IS THE SOLE PROPERTY OF AUTOMATED INDUSTRIAL MOTION. ANY REPRODUCTION IN PART OR AS A WHOLE WITHOUT THE WRITTEN PERMISSION OF AUTOMATED INDUSTRIAL MOTION IS PROHIBITED.	NAME	DATE	DURA-BOND SLIDE TITLE:			
	DRAWN	JMW			06/08/11	GEN II SLIDE
	CHECKED			SIZE	DWG. NO.	
	ENG APPR.	Wierengo	06/15/11	A	SW09-SL14-BL32-LH	-
MATERIAL	UNLESS OTHERWISE SPECIFIED:		SCALE: NONE			
ASSEMBLY	DIMENSIONS ARE IN INCHES		WEIGHT: 156.9 lbs.			
HARDEN	TOLERANCES:		SHEET 1 OF 1			
FINISH	ANGULAR: MACH ± 1/2 DEGREE					
	TWO PLACE DECIMAL ±.010					
	THREE PLACE DECIMAL ±.005					
	FOUR PLACE DECIMAL ±.0005					