

DET.	QTY.	DESCRIPTION
ASM	1	SW09-BL24 SLIDE BASE
ASM	1	SW09-SL18 SLIDE SADDLE

REV.	REVISION DESCRIPTION	DATE	APPROVED

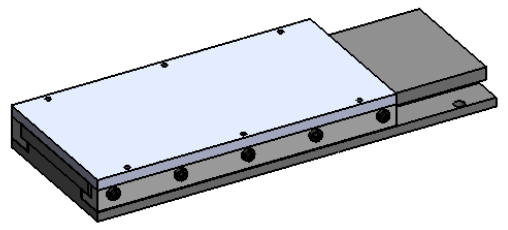
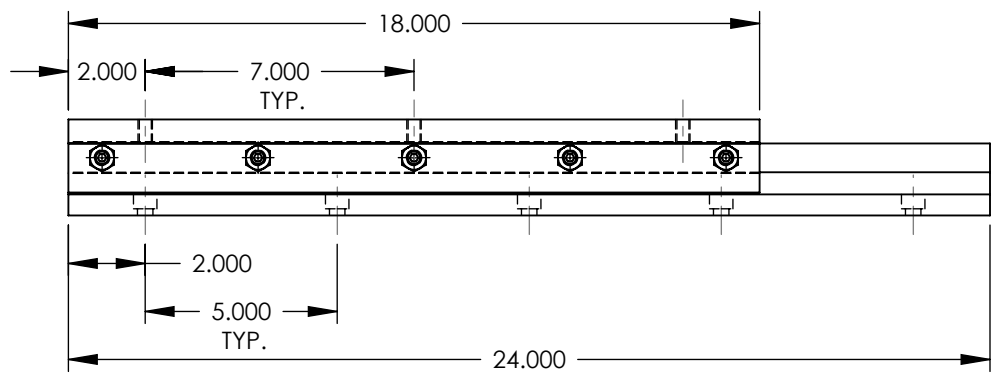
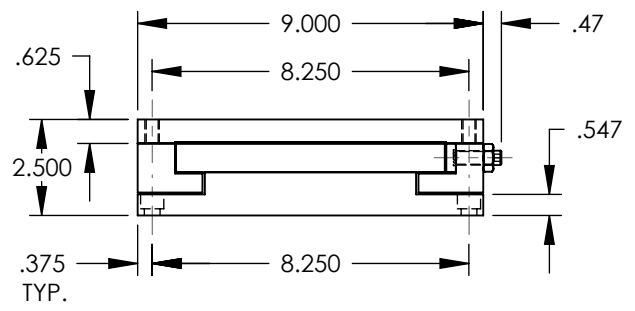
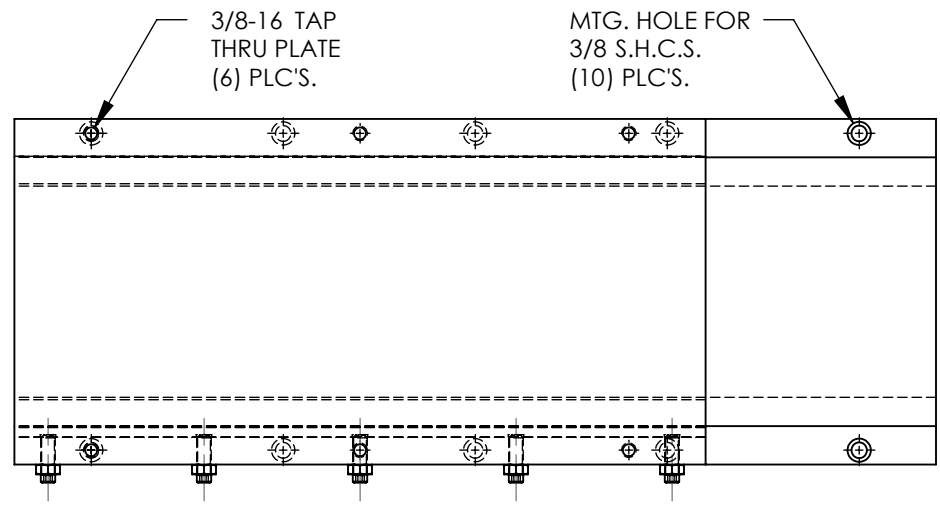

MODEL NAME: Gen2 SLIDE

PROPRIETARY AND CONFIDENTIAL THE INFORMATION CONTAINED IN THIS DRAWING IS THE SOLE PROPERTY OF AUTOMATED INDUSTRIAL MOTION. ANY REPRODUCTION IN PART OR AS A WHOLE WITHOUT THE WRITTEN PERMISSION OF AUTOMATED INDUSTRIAL MOTION IS PROHIBITED.	NAME	DATE	DURA-BOND SLIDE TITLE:		
	DRAWN	JMW			9/3/10
	CHECKED			GEN II SLIDE	
	ENG APPR.	Wierengo	10/1/10		
MATERIAL	UNLESS OTHERWISE SPECIFIED:		SIZE	DWG. NO.	REV
ASSEMBLY	DIMENSIONS ARE IN INCHES		A	SW09-SL18-BL24	-
HARDEN	TOLERANCES:				
FINISH	ANGULAR: MACH ± 1/2 DEGREE				
	TWO PLACE DECIMAL ±.010				
		THREE PLACE DECIMAL ±.005	SCALE: NONE	WEIGHT: 107.9 lbs.	SHEET 1 OF 1
		FOUR PLACE DECIMAL ±.0005			