

DET.	QTY.	DESCRIPTION
ASM	1	SW12-BL28 SLIDE BASE
ASM	1	SW12-SL24 SLIDE SADDLE WITH LOCK HANDLES
\$02	2	ADJUSTABLE HANDLE , KHB-102, 1/2-13 THREAD x 1.18 LG.

REV.	REVISION DESCRIPTION	DATE	APPROVED
------	----------------------	------	----------

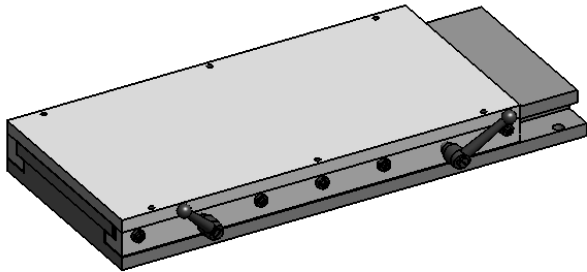
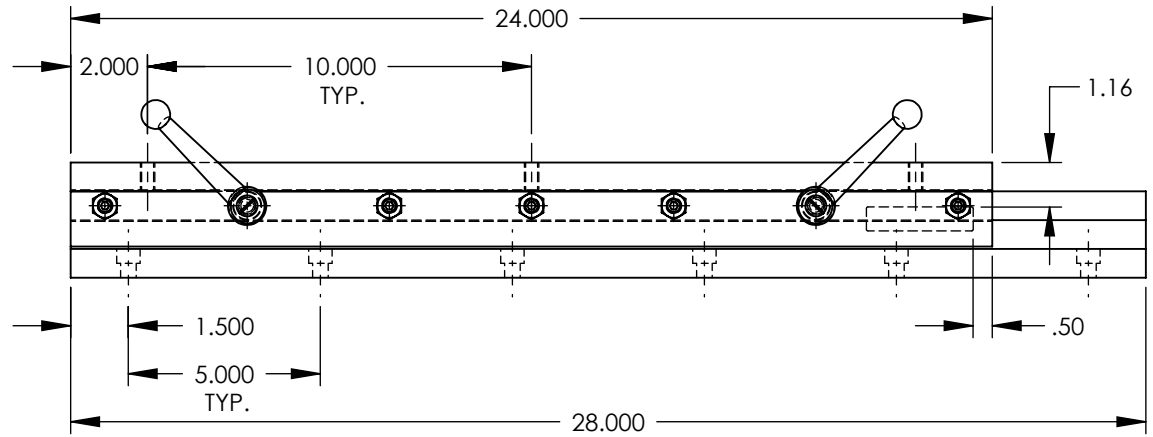
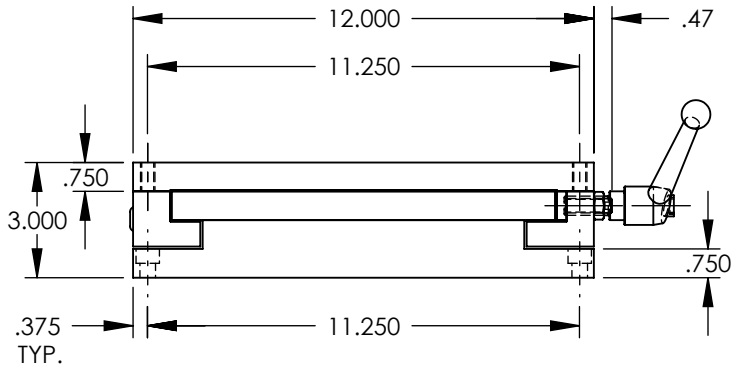
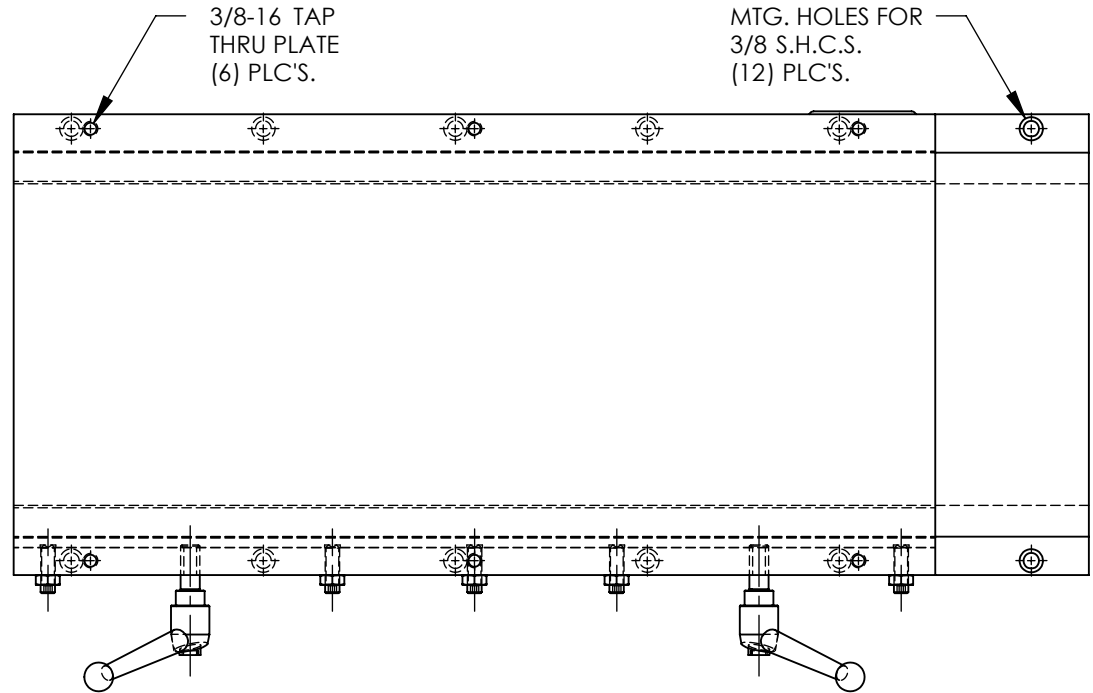

MODEL NAME: Gen2 SLIDE

PROPRIETARY AND CONFIDENTIAL
 THE INFORMATION CONTAINED IN THIS DRAWING IS THE SOLE PROPERTY OF AUTOMATED INDUSTRIAL MOTION. ANY REPRODUCTION IN PART OR AS A WHOLE WITHOUT THE WRITTEN PERMISSION OF AUTOMATED INDUSTRIAL MOTION IS PROHIBITED.

MATERIAL
ASSEMBLY
 HARDEN
 FINISH

	NAME	DATE
DRAWN	JMW	06/08/11
CHECKED		
ENG APPR.	Wierengo	06/15/11

UNLESS OTHERWISE SPECIFIED:
 DIMENSIONS ARE IN INCHES
 TOLERANCES:
 ANGULAR: MACH ± 1/2 DEGREE
 TWO PLACE DECIMAL ±.010
 THREE PLACE DECIMAL ±.005
 FOUR PLACE DECIMAL ±.0005

DURA-BOND SLIDE

TITLE:
GEN II SLIDE

SIZE	DWG. NO.	REV
A	SW12-SL24-BL28-LH	-

SCALE: NONE WEIGHT: 268.7 lbs. SHEET 1 OF 1