

DET.	QTY.	DESCRIPTION
ASM	1	SW12-BL32 SLIDE BASE
ASM	1	SW12-SL24 SLIDE SADDLE WITH LOCK HANDLES
\$02	2	ADJUSTABLE HANDLE , KHB-102, 1/2-13 THREAD x 1.18 LG.

REV.	REVISION DESCRIPTION	DATE	APPROVED
------	----------------------	------	----------

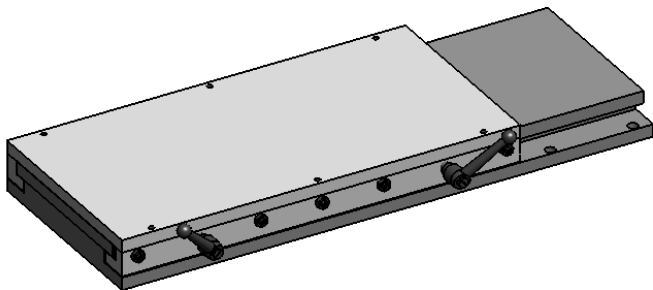
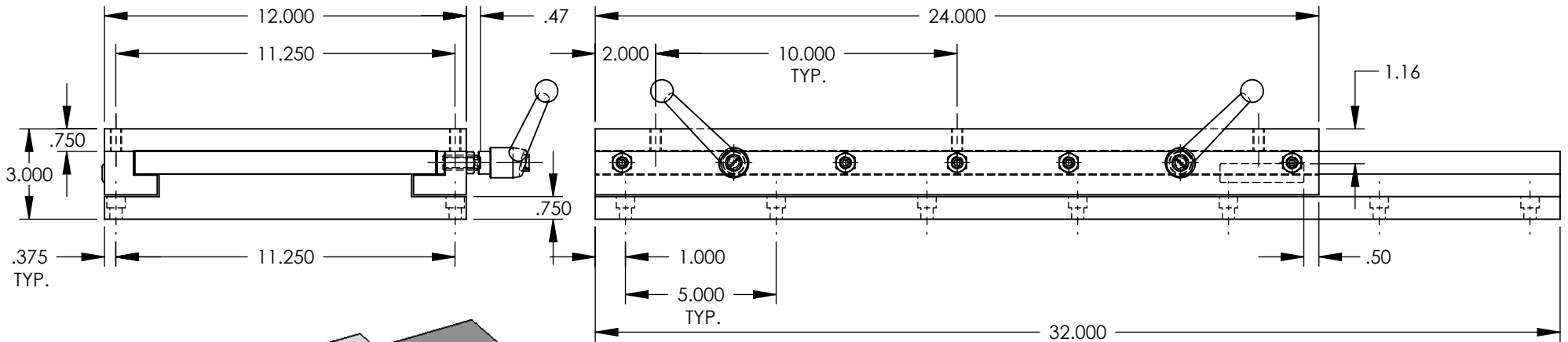
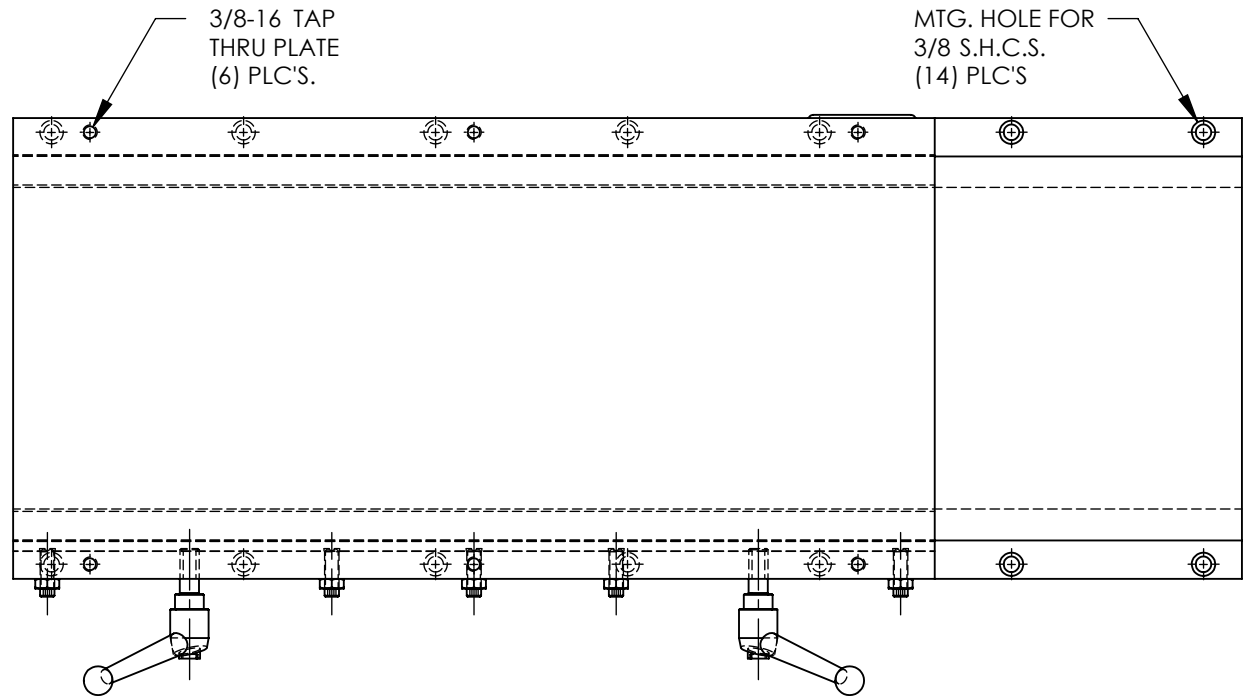

MODEL NAME: Gen2 SLIDE

PROPRIETARY AND CONFIDENTIAL THE INFORMATION CONTAINED IN THIS DRAWING IS THE SOLE PROPERTY OF AUTOMATED INDUSTRIAL MOTION. ANY REPRODUCTION IN PART OR AS A WHOLE WITHOUT THE WRITTEN PERMISSION OF AUTOMATED INDUSTRIAL MOTION IS PROHIBITED.	NAME	DATE	DURA-BOND SLIDE TITLE:		
	DRAWN	JMW			06/08/11
	CHECKED			GEN II SLIDE	
	ENG APPR.	Wierengo	06/15/11		
MATERIAL	UNLESS OTHERWISE SPECIFIED:		SIZE	DWG. NO.	REV
ASSEMBLY	DIMENSIONS ARE IN INCHES		A	SW12-SL24-BL32-LH	-
HARDEN	TOLERANCES:		SCALE: NONE	WEIGHT: 294.5 lbs.	SHEET 1 OF 1
FINISH	ANGULAR: MACH ± 1/2 DEGREE TWO PLACE DECIMAL ±.010 THREE PLACE DECIMAL ±.005 FOUR PLACE DECIMAL ±.0005				